

REV	REVISION DATE	RELEASE NUMBER	DESCRIPTION	DRAWN BY	CHECKED BY	APPROVED BY
00	6-8-00	2185	RELEASED/PRODUCTION	SJB	JCB	REF

CRIMPING

INSERT WIRE INTO THE END OF THE BUS BAR THAT HAS THE SQUARE INSPECTION HOLE. THE WIRE WILL BOTTOM OUT AND BE VISIBLE THRU THE SQUARE OPENING. CRIMP WIRE INTO BUS BAR.

THE CRIMP HEIGHT IS TO BE MEASURED FROM THE BOTTOM OF THE ROLL TO THE FLAT OF THE CRIMP., AS SHOWN IN FIGURE #1.

SPECIFICATIONS

WIRE SIZE (AWG)	8 GA.	10 GA.
CRIMP HEIGHT (IN.)	.193 ±.005	.170 ±.005
PULL TEST (LBS.) (UNSOLDERED)	70	70
STRIP LENGTH (IN.)	$\frac{22}{32}$	$\frac{22}{32}$

SOLDERING

ALL BUS BAR TO WIRE CRIMPS MUST BE SOLDERED. FAILURE TO DO SO MAY CAUSE FAILURE OF THE ASSEMBLY.

THE WIRE MUST BE CRIMPED INTO THE BUS BAR BEFORE SOLDERING. MAKE SURE THAT THE BUS BAR IS FREE OF OIL AND DIRT. DO NOT APPLY EXCESSIVE HEAT TO THE ASSEMBLY. AS DAMAGE TO THE WIRE INSULATION MAY RESULT.

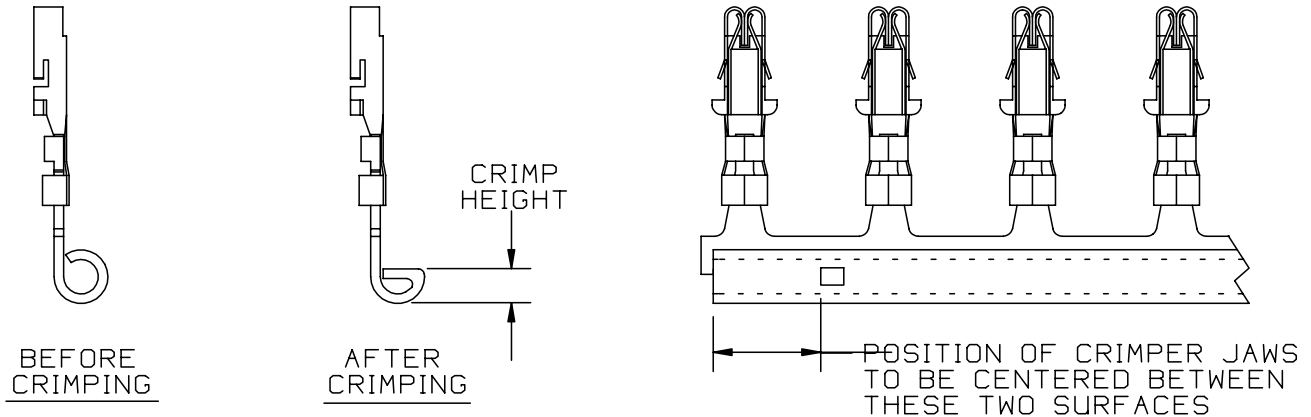

FIGURE 1

FILE # 000110-1	SHEET 1 OF 1	FARGO ASSEMBLY OF PA P.O. BOX 550 NORRISTOWN, PA 19404 PHONE: 610-272-6850 FAX: 610-272-6858
UNLESS STATED OTHERWISE; DIMENSIONS ARE IN INCHES. AND TOLERANCE ARE:	THIRD ANGLE PROJECTION 	OUR COMPANY GOALS 1. QUALITY 2. DELIVERY 3. FAIR PRICE 4. GOLDEN RULE
.X		
.XX	DRAWN SJB	DATE 1-10-00
.XXX	CHECKED JCB	DATE 1-00
FRACTIONAL +/- 1/64	APPROVED REF	DATE 1-00
ANGULAR +/- 30 MIN	SCALE: NONE	
THIS DOCUMENT CONTAINS PROPRIETARY INFORMATION AND IS NOT TO BE USED IN ANY WAY DETRIMENTAL TO THE INTEREST OF FARGO ASSEMBLY OF PA, INC.		TITLE: BUSS BAR CRIMPING AND SOLDERING SPECIFICATIONS
		DRAWING NUMBER 171-00-23
		REVISION 00